



# AHL-LIGHT 15

LED DROP LIGHT

[ahlbergcameras.com/products/lights/ahl-light-15](http://ahlbergcameras.com/products/lights/ahl-light-15)



The AHL-LIGHT 15 is a small LED light that can illuminate narrow working areas.

## MORE INFORMATION ABOUT AHL-LIGHT 15

### APPLICATIONS

- Underwater nuclear drop light
- Ideal for work in reactor and fuel pools
- Works together with a separate power supply unit

### BENEFITS

- Low maintenance costs due to its long life-time
- 15 000 lumen light output
- FME approved design – no loose parts can enter the pool water

## SPECIFICATIONS

### PHYSICAL CHARACTERISTICS

Width	60 mm
Height	207 mm
Weight	1.2 kg
Housing material	Anodized aluminum, Stainless steel
Front glass material	PUR

### LIGHTING FEATURES

Type	LED 100-240 VAC, 50/60 HZ
Typical luminous flux	15 000 lumen
Life time	>50 000 h

### ENVIRONMENTAL TOLERANCES

Radiation tolerance (total dose)	50 000 Gy (5 000 000 rad)
Maximum temperature	50°C, 70°C for short periods (122°F, 158°F)
Water Tightness	3.5 bar

### CABLE FEATURES

Maximum cable length	425 m
----------------------	-------

*We reserve the right to alter specifications without prior notice*

## AHL-LIGHT 15 IMAGES

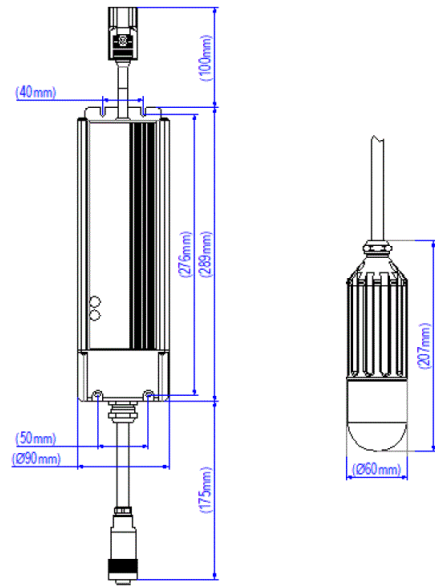

*We reserve the right to alter specifications without prior notice*